

NISSAN
FORKLIFT

WCN Series

Walkie Counterbalanced Stacker

3,000 & 4,000 lb.
Capacities



Mast Specifications & Rated Capacities

Dimensions

WCN-30 / WCN-40

Mast Type	Maximum Fork Height	Overall Height Lowered	Free Lift*	Rated Capacity at 24" Load Center	
				WCN-30	WCN-40
TWO STAGE (Lo Free Lift)	105.5 (2680)	72 (1829)	5.5 (140)	3000 (1361)	4000 (1814)
	115.5 (2934)	77 (1956)	5.5 (140)	3000 (1361)	4000 (1814)
	127.5 (3239)	83 (2108)	5.5 (140)	3000 (1361)	4000 (1814)
	139.5 (3543)	89 (2261)	5.5 (140)	3000 (1361)	4000 (1814)
	151.5 (3848)	95 (2413)	5.5 (140)	3000 (1361)	3950 (1792)
TWO STAGE (High Free Lift)	105.5 (2680)	72 (1829)	51 (1295)	3000 (1361)	4000 (1814)
	115.5 (2934)	77 (1956)	56 (1422)	3000 (1361)	4000 (1814)
	127.5 (3239)	83 (2108)	62 (1575)	3000 (1361)	4000 (1814)
	139.5 (3543)	89 (2261)	68 (1727)	3000 (1361)	4000 (1814)
	151.5 (3848)	95 (2413)	74 (1880)	3000 (1361)	3950 (1792)
THREE STAGE	155.5 (3950)	72 (1829)	51 (1295)	3000 (1361)	4000 (1814)
	170 (4318)	77 (1956)	56 (1422)	2700 (1225)	3750 (1701)
	188 (4775)	83 (2108)	62 (1575)	2475 (1123)	3450 (1565)
	202 (5131)	89 (2261)	68 (1727)	2325 (1055)	3275 (1486)
	216 (5486)	95 (2413)	74 (1880)	2175 (987)	2950 (1338)

*Free lift fork height does not include backrest extension.

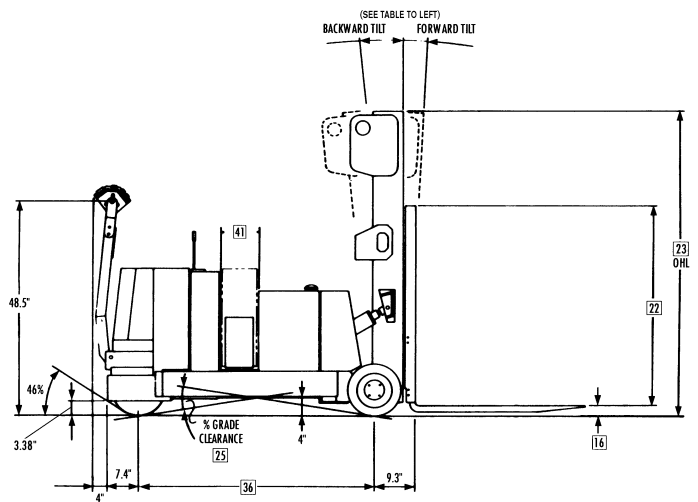
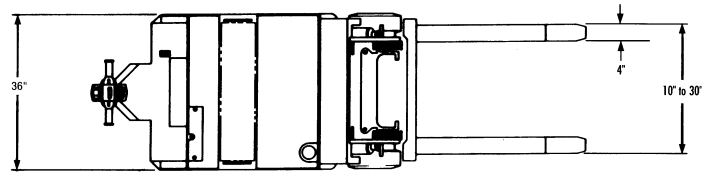

Mast Tilt

Lift Height	Forward	Back
Up to 130"	3°	6°
131" to 160"	2°	4°
Over 160"	1°	5°

Aisle Specifications

Right Angle Stacking Aisle Requirements*

WCN-30

Load Width	Load Length					
	30"	32"	36"	40"	42"	48"
30"	103.2	105.0	108.8	112.6	114.5	120.3
32"	103.5	105.4	109.1	112.9	114.8	120.6
36"	104.3	106.1	109.8	113.6	115.5	121.1
40"	105.2	107.0	110.6	114.3	116.1	121.8
42"	105.6	107.4	111.0	114.7	116.5	122.1
48"	107.1	108.9	112.4	115.9	117.7	123.2

WCN-40

Load Width	Load Length					
	30"	32"	36"	40"	42"	48"
30"	110.4	112.3	116.1	119.9	121.8	127.6
32"	108.0	112.6	116.4	120.2	122.1	127.8
36"	111.6	113.4	117.1	120.8	122.7	128.4
40"	112.4	114.2	117.9	121.5	123.4	129.0
42"	112.9	114.7	118.3	121.9	123.8	129.4
48"	114.4	116.1	119.6	123.2	125.0	130.5

*Based on 4" clearance between pallets.

90° Intersecting Aisle Requirements*

WCN-30

Load Width	Load Length					
	30"	32"	36"	40"	42"	48"
30"	58.1	58.5	59.4	60.5	61.1	63.0
32"	58.4	58.9	59.8	60.9	61.5	63.4
36"	59.2	59.7	60.6	61.7	62.3	64.2
40"	61.4	61.9	62.9	64.0	64.6	66.5
42"	62.6	63.0	64.0	65.1	65.7	67.7
48"	66.0	66.4	67.5	68.6	69.7	71.3

WCN-40

Load Width	Load Length					
	30"	32"	36"	40"	42"	48"
30"	61.5	61.8	62.7	63.6	64.1	65.7
32"	61.8	62.2	63.0	64.0	64.5	66.1
36"	62.6	63.0	63.8	64.8	65.3	66.9
40"	64.8	65.2	66.0	67.0	67.5	69.2
42"	65.9	66.3	67.1	68.1	68.6	70.3
48"	69.3	69.7	70.5	71.5	72.0	73.8

* Aisle dimensions are minimum. Nissan recommends 6"-10" additional clearance for ease of operation.

Dimensions for both 8.25" and 13.5" wide battery compartments.

Add 2" for side shifter.

3,000 - 4,000 lb. capacities

Main Truck Specifications									
CHARACTERISTICS	1	Manufacturer's Name			Nissan		Nissan		1
	2	Model	Model designation		WCN-30		WCN-40		2
	3	Load Capacity	Rated capacity	lb (kg)	3000 (1500)		4000 (2000)		3
	4	Load Center	Distance	in (mm)	24 (600)		24 (600)		4
	5	Power Type	Electric	volt	12	24	12	24	5
	6	Operator Type			Walkie Counterbalanced		Walkie Counterbalanced		6
	7	Tire Type	Front and rear		Poly / Poly		Poly / Poly		7
	8	Wheels	Number (x=driven) - front/rear		2 / 1x		2 / 1x		8
DIMENSIONS	9	Mast	Max. fork height (MFH)	in (mm)	105.5 (2680)		105.5 (2680)		9
	10		Freelift (FL)	in (mm)	51 (1295)		51 (1295)		10
	12	Forks	Thickness x width	in (mm)	1.6 x 4.2 (40 x 106)		1.6 x 4.2 (40 x 106)		12
	13		Length	in (mm)	42.1 (1070)		42.1 (1070)		13
	14		Min. spread (o.d.)	in (mm)	10 (254)		10 (254)		14
	15		Max. spread (o.d.)	in (mm)	30 (762)		30 (762)		15
	16		Fork lowered height	in (mm)	2.0 (51)		2.0 (51)		16
	19		Overall Dimensions	Length (to face of forks)	in (mm)	70.5 (1790)		77.7 (1974)	
	20	Length (to end of forks)		in (mm)	112.2 (2858)		119.7 (3040)		20
	22	Height - top of standard LBR		in (mm)	48 (1219)		48 (1219)		22
	23	Mast lowered (OHL)		in (mm)	72 (1829)		71 (1803)		23
	24	Mast extended with LBR		in (mm)	153.5 (3899)		153.5 (3899)		24
	25	Grade Clearance	8.25" and 13.5" battery compartments	%	15%		13%		25
	26	Turning Radius	Minimum outside	in (mm)	61.13 (1553)		68.38 (1737)		26
	27	Min. Right Angle Stack	48" L x 40" W pallet (add clearance)	in (mm)	121.8 (3094)		129.0 (3277)		27
	28	Truck Weight	103.5" Mast, empty, no battery	lb (kg)	5027 (2282)		5099 (2315)		28
PERFORMANCE	29	Speeds	Travel - full load	mph (kph)	2.1 (3.4)	2.1 (3.4)	2.0 (3.2)	2.0 (3.2)	29
	30		Travel - no load	mph (kph)	2.4 (3.9)	2.5 (4.0)	2.3 (3.7)	2.5 (4.0)	30
	31		Lift - full	fpm (mm/sec)	16 (81)	31 (157)	12 (61)	30 (152)	31
	32		Lift - empty	fpm (mm/sec)	24 (122)	42 (213)	25 (127)	43 (218)	32
	33		Lower - full	fpm (mm/sec)	47 (239)	47 (239)	54 (274)	54 (274)	33
	34		Lower - empty	fpm (mm/sec)	26 (132)	26 (132)	31 (157)	31 (157)	34
CHASSIS & WHEELS	35	Overall Width	Width	in (mm)	36 (915)		36 (915)		35
	36	Wheelbase	Distance between axles on centers	in (mm)	53.75 (1365)		61.0 (1550)		36
	37	Tire Size	Drive tire	in (mm)	12 x 4.5 (305 x 114)		12 x 4.5 (305 x 114)		37
	38		Load wheels	in (mm)	12 x 4.5 (305 x 114)		12 x 4.5 (305 x 114)		38
	39	Service Brake	Type		Drum and Shoe		Drum and Shoe		39
BATTERY	40	Type			Lead Acid		Lead Acid		40
	41	Compartment Size	Width x Height	in (mm)	32 x 31 (813 x 788)		32 x 31 (813 x 788)		41
			Length	in (mm)	8.25 (210)	13.5 (343)	8.25 (210)	13.5 (343)	
	42	Amp Hr Capacity	Min / Max (6-hr)	Ah	375 / 750	450 / 750	375 / 750	450 / 750	42
	43	Weight	Min / Max	lb (kg)	410 / 725 (185 / 330)		410 / 725 (185 / 330)		43
	44	Lead Length	Position "B"	in (mm)	20 (508)		20 (508)		44
45	Connector		type	SB-175 Grey		SB-175 Grey		45	

NOTE: 12-Volt models are standard.

24-Volt model specifications based on larger 32" x 13.5" x 31"H battery compartment size.

Technical Information **WCN Series**

Standard Equipment

- 12-volt electrical system
- Premium heavy-duty motor
- Curtis PMC 1205 transistor travel controller
- Reversing switch in handle
- Electronic horn
- Curtis 701 solid state LCD hour meter
- Key switch
- Battery compartment: 32" x 8.25" x 31"
- Clam-type battery retainers
- Minimum battery weight: 410 lbs.
- SB-2 Battery connector (175 Amp – grey)
- 2 Spool hydraulic control valve
- Oil filter in hydraulic system
- 48" h x 32.6" w load backrest
- Duplex FFL mast: 72" OHL / 105.5" MFH / 51" FL
- Fork lengths: 30", 36", 42"
- Fork spacing: 10" min. to 30" max. o.d.
- Poly drive tire – 12" x 4.5"
- Rubber load wheels – 12" x 4.5"

Optional Equipment

- 24-volt electrical system with 13.5" wide battery compartment
- Fuel gauge type battery discharge indicator
- Battery discharge indicator with lift interrupt
- Battery compartment rollers with drop-in gates
- Cold storage protection
- Side shifter with single function hydraulics and IHR

Steer Control Features

Steering handle with outside stationary grips provides low-effort pull-down into the operating range. Thumb-operated butterfly speed controls inside the control head provide easy and precise truck control. Large safety reversing switch, on the control handle, reverses truck travel direction if operator contact is made. Control head features lift, lower, and horn buttons within convenient operator reach. Gas charged cylinder returns the handle with uniform force, while a rubber stop at the end of travel prevents switch shock.

Electrical

12-volt electrical system with heavy-duty series wound class 'H' insulated drive motor. PMC transistor travel controller for smooth, controlled acceleration, infinitely variable speed control, and increased energy efficiency. Key switch and solid state LCD hour meter are standard. Steer handle wiring harness constructed of extra flexible stranded tinned copper conductor wiring with silicone insulation for increased durability and reduced maintenance.

Drive Unit Assembly

Exclusive balanced drive system designed with drive motor, transmission and drive tire mounted in a vertical column. This stationary design greatly reduces steer effort, unbalanced torque conditions, and cable flexing, for enhanced reliability and reduced maintenance costs.

Brake System

Dual braking positions within upper and lower handle movement range enhance operating efficiency. The 7" diameter brake drum provides excellent braking response, with the largest braking surface in its class.

Hydraulic System

Hydraulic system features heavy-duty lift pump and motor, overload protection valve, solenoid release valve for lowering, check valve, and flow regulator. Return line filtering protects the system against environmental contaminants.

Steering

190° steering arc (95° each side of center) allows for precise maneuvering in tight spaces for increased operator efficiency. Steer handle is mounted to the bottom of drive unit for maximum leverage and steering ease.

Frame Assembly

Rugged frame with high under clearance for tough dock applications. Steel covers for rugged durability and component protection. Powder coat paint for a durable, high gloss, scratch resistant finish.

Battery Compartment

The battery compartment features unique battery retention gates that eliminate side-to-side battery movement. Clam-type steel battery retainers keep the battery secure in the battery compartment and allow for quick and easy battery change without the use of hand tools.

Ease of Service

Removing five bolts allows quick and simple drive tire replacement. The hub has a built-in drive wheel puller to simplify the job. One screw removal, simplifies drive motor brush inspection. Lubrication fittings are easily accessible with the truck upright and the battery in place. Removal of four hood bolts allows quick access to internal components. Number coded electrical wiring simplifies wiring harness maintenance. One nut removal of the brake drum allows easy access for periodic inspection and maintenance.

Nissan Forklift Corporation
240 N. Prospect Street
Marengo, IL 60152 USA
Phone (815) 568-0061
Fax (815) 568-0179
www.nissanforklift.com

Nissan Forklift Corporation reserves the right to make product changes relating to colors, equipment or specifications without notice. For more information, contact your Nissan Forklift representative.

NISSAN
FORKLIFT