

NISSAN
FORKLIFT

SPN Series

Low-Lift, Center-Control, Walkie/Rider Pallet Trucks

6,000 & 8,000 lb.
Capacities



Dimensions

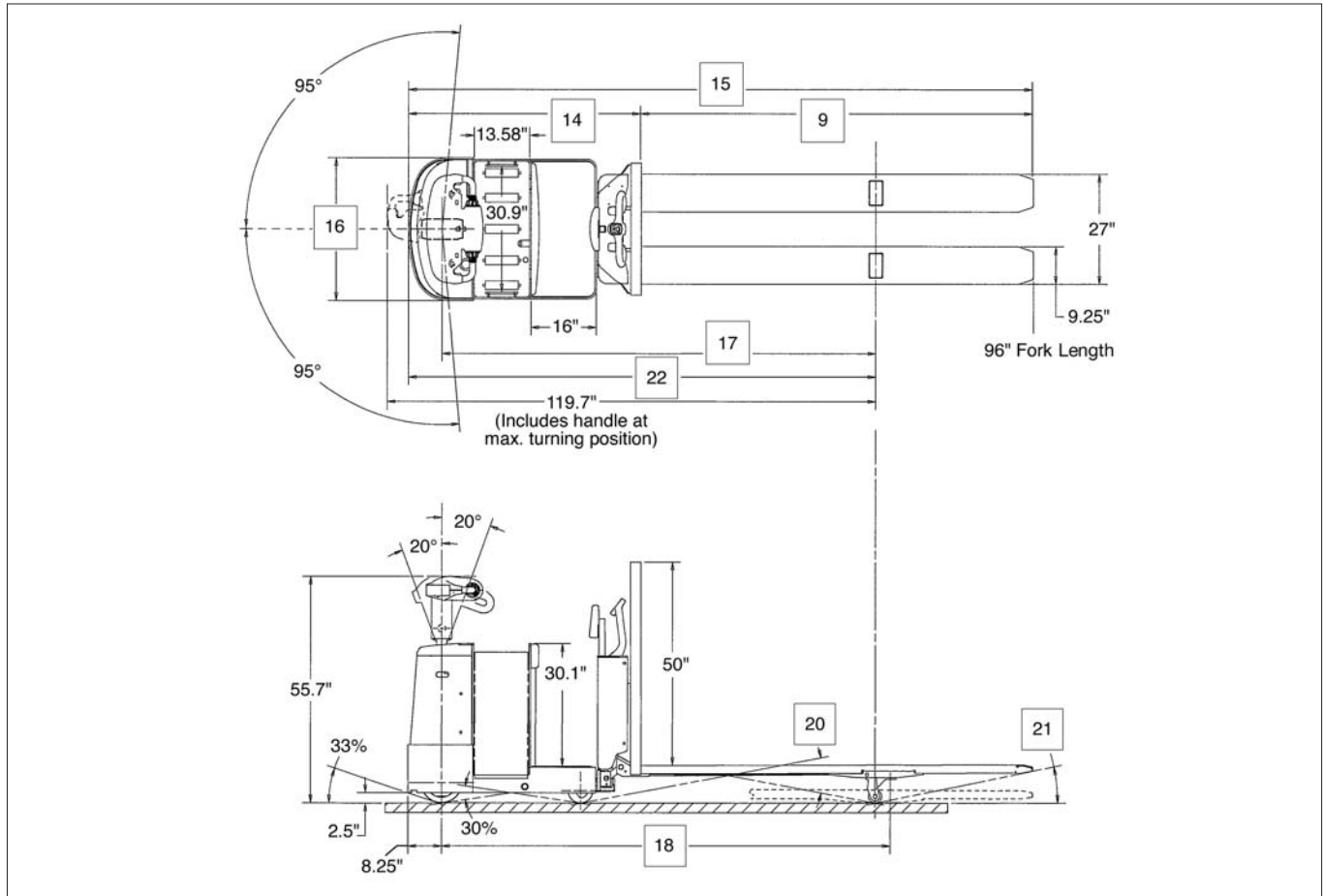

			Single Pallet	Double Pallet		
9	Nominal Fork Length	in (mm)	48 (1219)	84 (2134)	96 (2438)	9
18	Wheelbase (Forks lowered)	in (mm)	97.2 (2468)	110 (2792)	110 (2792)	18
20	Grade Clearance	Between casters & load wheels	57	40	40	20
21		From load wheel to fork tip	70	30	20	21
22	Turning Radius	in (mm)	93.5 (2375)	114.5 (2910)	114.5 (2910)	22
23	Right Angle Stacking Aisle*	40", 42", 48" Load widths	108 (2750)	146 (3710)	158 (4015)	23
	90° Intersecting Aisle *	40" Load width	78 (1980)	89 (2260)	91 (2315)	
		42" Load width	79 (2010)	91 (2315)	92 (2340)	
		48" Load width	82 (2085)	94 (2390)	95 (2415)	

*Add 6-8" for ease of operation. Includes 1" clearance on each side of load.

Intersecting Aisle Requirements

A	B	C
Working Aisle in (mm)	Rack Width ¹ in (mm)	Intersecting Aisle ² in (mm)
96 (2440)	102 (2590)	118.6 (3013)
102 (2590)	102 (2590)	110.5 (2806)
108 (2745)	102 (2590)	104.3 (2650)

¹ Rack width calculated using 48" pallets and additional 6" needed for bracing.
² Minimum required aisle size to make a turn from one adjacent aisle to the next.

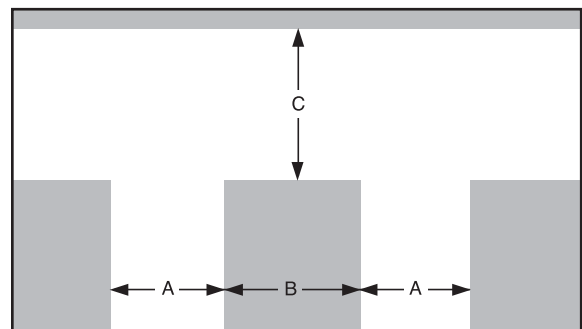

6,000 & 8,000 lb. capacities

Main Truck Specifications

				Nissan	Nissan	
CHARACTERISTICS	1	Manufacturer		Nissan	Nissan	1
	2	Model	Model designation	SPN60	SPN80	2
			Long model code	SPTT1W3G60NV	SPTT1W3G80NV	
	3	Load Capacity	lb (kg)	6000 (3000)	8000 (4000)	3
	4	Power Type	Electric	24 Volt	24 Volt	4
	5	Operator Type	Stand-up	Walkie/Rider	Walkie/Rider	5
	6	Tire Type		Solid Rubber	Solid Rubber	6
FORKS	7	Wheels	Number - front/rear	3 / 2	3 / 2	7
	8	Size	Outside spread	in (mm)	27 (686)	8
	9		Nominal length	in (mm)	96 (2438)	9
	10	Height	Raised position	in (mm)	9.25 (235)	10
	11		Lowered position	in (mm)	3.25 (82.5)	11
	12	Individual Fork Width	in (mm)	9.25 (235)	9.25 (235)	12
DIMENSIONS	13	Total Lift	During travel	in (mm)	6 (152)	13
	14	Overall Dimensions	Head length	in (mm)	56.9 (1444)	14
	15		Length with forks	in (mm)	152.9 (3883)	15
	16		Width - chassis	in (mm)	35.1 (890)	16
	17	Wheelbase	Forks raised	in (mm)	106.2 (2700)	17
	18		Forks lowered	in (mm)	110 (2792)	18
	19	Grade Clearance	Under chassis	%	30	19
	22	Turning Radius	Minimum outside	in (mm)	114.5 (2910)	22
	23	Right Angle Stacking ¹	40" x 48" pallet	in (mm)	158 (4015)	23
	24	Truck Weight	With standard forks	lb (kg)	1930 (875)	24
SPEEDS	25	Tires / Wheels	Drive tire	in (mm)	4 x 10 (102 x 254)	25
	26		Load Wheels	in (mm)	3.25 x 6 (82 x 152)	26
	27	Speed - Travel	Gear ratio 14.1:1			27
			No load	mph (km/h)	8 (13)	
	Full load		mph (km/h)	5.8 (9.4)	5.5 (8.9)	
BATTERY	28	Battery Compartment ²	L x W x H	in (mm)	32 x 13.5 x 31 (813 x 343 x 803)	28
	29	Amp Hr Capacity	Min / Max (6-hr)	Ah	450 / 750	29
	30	Weight	Min / Max	lb (kg)	854 / 1550 (387 / 703)	30
	31	Lead Length	Position "B"	in (mm)	20 (508)	31
	32	Connector		type	SB 175 Red	32

¹Add 6-8" for ease of operation. Includes 1" clearance on each side of load.

²Compartment dimensions shown without battery gate. (31" x 13.5" x 31" with gates.)

Fork Length Selection Guide

Single Pallet Handling:

Size the forks to the exact pallet length. The load wheels will drop in the second opening of the pallet.

Double Pallet Handling:

Size the forks to the exact pallet combination length. The load wheels should be specified to drop in the first opening of the second pallet to reduce the turning radius of the truck.

Contact your Nissan Forklift sales representative for details about load wheel location or fork length requirements for your application.



Steerhead includes two butterfly controls, allowing thumb or fingertip actuation of travel and direction.



Optional convenience tray keeps operator items organized.



Optional battery rollers make change out quick and easy.

Technical Information **SPN series**

Standard Equipment

1. 24-volt electrical system
2. Separately excited drive motor and control system
3. Programmable speed settings up to 8.0 mph
4. Coast control and integrated sidetracker
5. Adjustable steer head with low effort switches
6. 96" forks with 50" load backrest
7. Environmental protection package for cooler and freezer applications (to -20°F / -28.9°C)
8. Spyglass display readout includes battery discharge indicator with lift lockout, 3 hour meters and scheduled maintenance timer
9. On-board diagnostics
10. Electronic brake system; Push button parking brake
11. Key switch
12. Cushioned platform mat for greater operator comfort
13. Heavy duty steel hood and large front bumper
14. Padded front wall and backrest
15. SB-2 (175 Amp Red) connector
16. 3.25" x 6" polyurethane load wheels with string guards
17. Solid rubber drive tire
18. Heavy-duty caster wheels

Optional Equipment

1. Battery compartment rollers and removable drop-in side gates
2. Fixed steer head
3. 60" load backrest
4. Convenience tray
5. Toggle switch in lieu of key switch
6. Stainless steel linkage pins and axles
7. High load poly or vulkanol load wheel options
8. Non-marking, treaded (8000 lb. only), or flat poly drive tire options
9. Variety of paint options available
10. Water resistant package

Operator Area and Control Features

T-style, adjustable steer head combined with cushioned platform and fully padded compartment provide an impressive workplace to achieve maximum operator comfort and reduced fatigue resulting in sustained productivity.

The steer head's wide, 190° steering arc allows for precise maneuvering in tight spaces with minimal effort. Its ergonomic layout of soft touch switches also includes two large thumb-actuated butterfly speed controls for simple operation. Raise, lower and fixed speed reverse buttons offer more efficient load handling. The truck's standard coast control with sidetracker offers increased efficiency during low level order picking.

Separate controls mounted to a soft grip grab bar facilitate reverse operation, including lift and lower, horn and fixed reverse travel speed. Roomy, low profile compartment (8.8" platform height) permits easy entry/exit and walk-through.

Electrical

Heavy-duty 24 volt electrical system incorporates a rugged 5.1 HP drive motor to handle a variety of demanding applications. Separately excited control system offers fast travel speeds for exceptional operator efficiency, with proportional plugging for smooth, controlled stops. All components are designed to withstand cold and/or freezer applications to -20° F (-28.9° C). Elimination of contactors and enhanced thermal capabilities mean optimum performance and minimal downtime. On-board diagnostics and automatic replication of truck settings simplify fleet maintenance.

Nissan Forklift Corporation
240 N. Prospect Street
Marengo, IL 60152 USA
Phone (815) 568-0061
Fax (815) 568-0179
www.nissanforklift.com

Nissan Forklift Corporation reserves the right to make product changes relating to colors, equipment or specifications without notice. For more information, contact your Nissan Forklift representative.

Brake System

Electrical disc system incorporates regenerative motor torque prior to brake actuation for less component wear and longer life. System eliminates needed adjustments and hydraulic components for reduced maintenance.

Frame Assembly

Exclusive articulated frame design with 5-point suspension incorporates drive wheel and swivel caster wheels that are separate from the rear load bearing frame, permitting smooth, independent movement of rear frame and chassis for easier negotiating over dockplates and uneven floors.

Fork Assembly

Forks are formed from ¼" plate steel, designed with a reinforced tip for durability. Proven push-type fork linkage includes rugged 1½" x 1½" tie rods that stay within fork plane to absorb high impact shocks caused by ramp entry or poor floor conditions. Alloyed steel fork slides make rollers unnecessary. Tie rods are positively aligned and pinned to eliminate the need for field adjustments. Full length angle iron reinforcement increases torsional strength to resist twisting. Forks are welded beneath the battery compartment, resulting in stronger, more rigid construction for increased durability and longer life.

Tires

6" wide poly load wheels with string guards offer increased floor surface contact and eliminate debris from getting into axles and bearings. Load wheels swing through a small 7" arc to achieve a full 6" lift, helping prevent bottom pallet board damage.

Caster Design

Heavy duty, shim-free casters mounted under the rider platform provide a 2" up/down travel stroke for maximum stability in rough floor conditions. Threaded fastener design means quick adjustments are easily made.

Hydraulics

Heavy duty integrated hydraulic pump and motor design features an overload valve to protect hydraulic components, and directional valves including flow regulator and solenoid release valve. A lift circuit in the controller cuts out lift at maximum elevation to prevent excessive amp draw.

Drive Unit Assembly

Vertically-mounted balanced drive system with drive motor, transmission and drive tire reduces steer effort and prevents unbalanced torque conditions. Five-bolt assembly simplifies drive tire replacement when needed. Drive motor brush inspection is easily accessible by removing 2 bolts. Internal fan provides additional ventilation of motor and components to keep system running cooler resulting in better performance and lower overall ownership costs.

Ease of Maintenance

One-piece cover makes access to the drive unit assembly quick and easy. Combined number and color-coded wiring system simplifies servicing. All lubrication fittings are easily accessible with the truck upright and battery in place. Maintenance reminders can be set using the handset tool.

Customized Operational Settings

Use of handset tool allows customized settings of basic operational functions, including: forward and reverse speeds, acceleration rate, plugging. Optional beeper for travel (reverse and/or forward) can be enabled. Battery discharge parameters can be adjusted.